

Articulated Keyboard Station - Arm



Articulated Keyboard Station - Arm

Quick Overview

- This product is the easiest and most convenient computer keyboard arm mechanism.
- This product is very easy to fit.
- Special system-32 mounting plate provided to mount the required platform.
- Excellent for users who are at their computers for long periods of time (at home or at the office).
- Stable, solid and durable design.
- Adjustments can be made simultaneously ? keyboard can be tilted and rotated to the angle that is most comfortable for the user.
- Adjustments are spring assisted to help counter balance.
- Available in Anthracite.



Specification

Code	Finish
AKS-S4	Anthracite

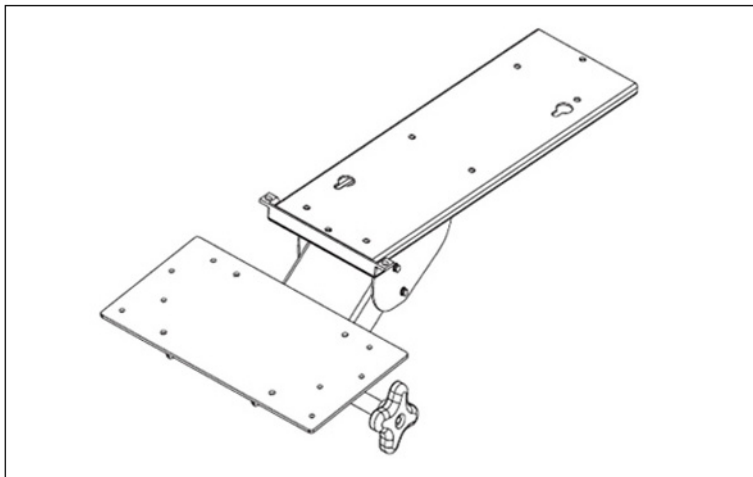

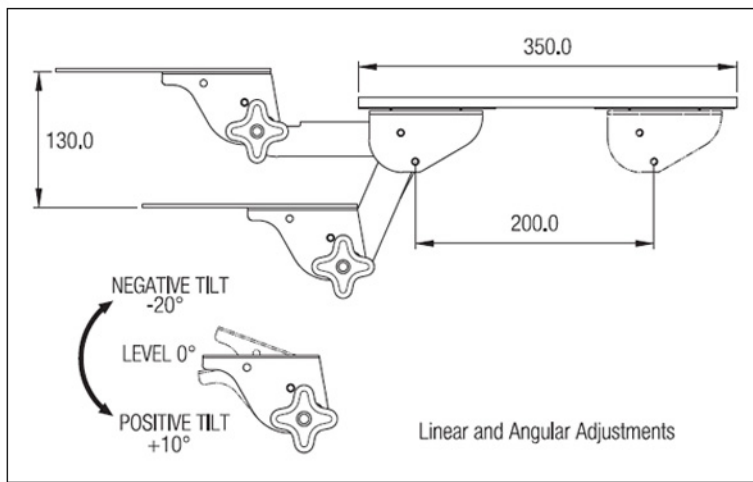

Fitting Instructions

- Fit the Retainer Plate under the table top leaving 15 mm from the front. Fit the Stopper Bush at the rear end. (Ref. Fig.1) Use pan head wood screws provided.
- Slide the Arm assembly into the Retainer Plate.(Ref. Fig. 2).
- Screw the plastic Front Stopper onto the front end of the Retainer Plate.(Ref. Fig.3).

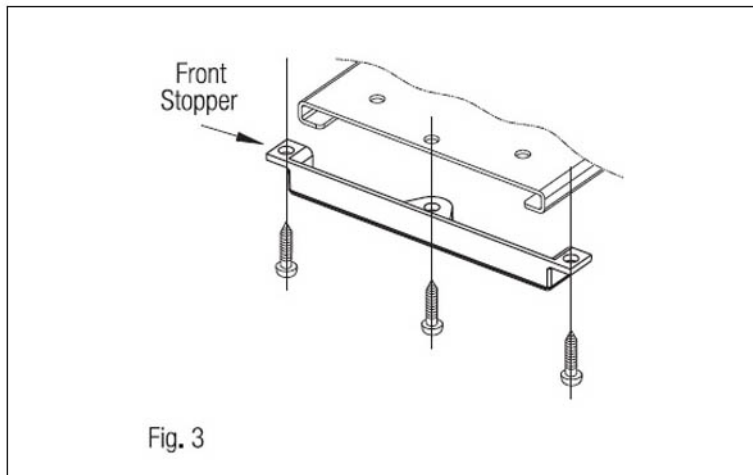
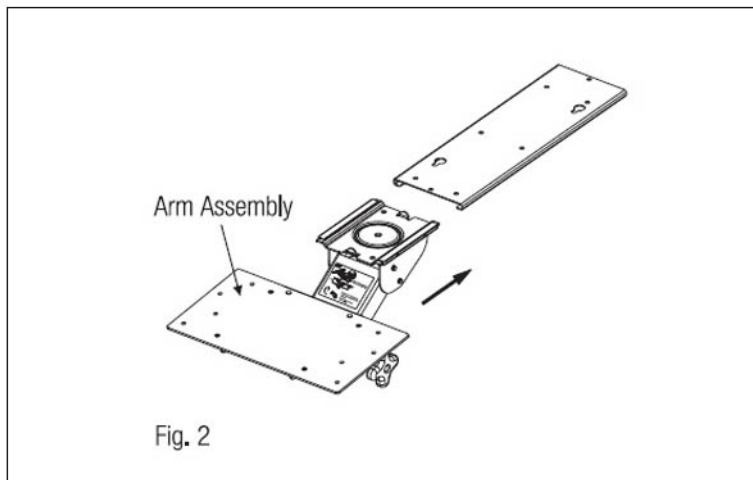
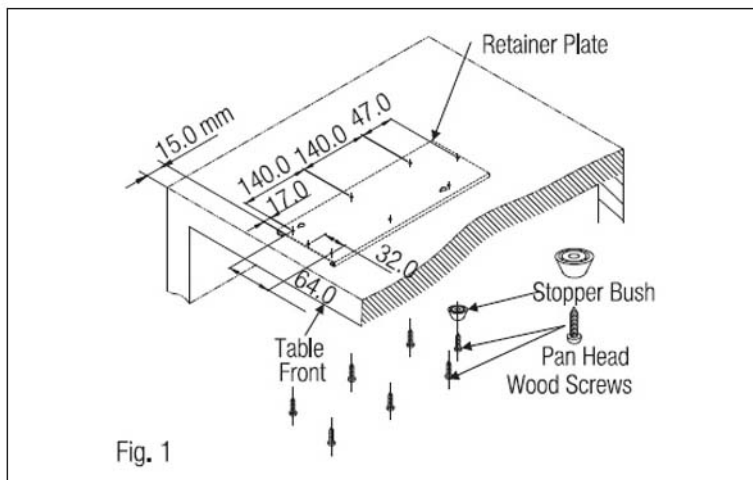

Care Instructions

- Please follow the fitting instructions carefully. Not following these instructions can lead to damage of your keyboard as well as the product.

- To clean when required, wipe with a dry cloth or lightly brush dust off with a clean and dry brush.
- Do not clean, paint, engrave or use any chemicals on the product.

Warranty

- Our Products comes with a 12 month warranty against any manufacturing defects.
- The warranty does not cover damages due to incorrect and inaccurate installation of the product.
- For any guidance or help required with installation, please email us at help@ebco.in with your order number and a scanned copy of the invoice.
- The warranty does not cover any usage of the product beyond its intended use and wear and tear in the natural course of product usage.
- The warranty is only valid against an original invoice received at the time of purchase.

Returns

- All sales are final, except in the case of any manufacturing defects. For any manufacturing defects, we offer easy replacements.
- In the case of transit damage, it rests solely at the discretion of Ebco to process any replacements on a case-by-case basis.
- In case, you receive a defective or damaged product , please contact us within 7 days of receipt. Email us a few photographs with the order number and a scanned copy of the invoice to help@ebco.in.
- We will assess the damage and revert within 24 hours. We will either arrange to collect the product and send you a replacement free of charge or just send you a replacement part.